



iT56051

Three Phases Intelligent Power Module

Datasheet Rev. 0.6

1. Description

The iT56051 is a three-phase, intelligence power module. It is composed of temperature sensor, MOSFET, gate driver and control logic which can provide minimal components of total BOM to save the total cost. The iT56051 embedded 600V HVIC gate driver with bootstrap diode. Built-in 5A/600V fast recovery MOSFET to reduce switching loss. The gate driver sourcing / sinking current is fine tuned to lower the EMI. The iT56051 is equipped TS (temperature sensor), UVLO (under voltage lockout) protections. Three independent low side MOSFET source paths for the current sensing application.

2. Features

- 5A/600V Fast Recovery MOSFET
- Floating Channel Designed for Bootstrap Operation to +600V
- Under Voltage (UVLO) Protection
- Bootstrap Diodes Built-in with Current Limiting Resistor
- Input interface: 3.3V, 5V Line
- 3-Phase Independent Current Detection
- Temperature Sensor
- Soft Driving for Low EMI
- Insulation Voltage Standing: 1500Vrms
- SOP-23H Package
- UL 94V-0 Compound Material

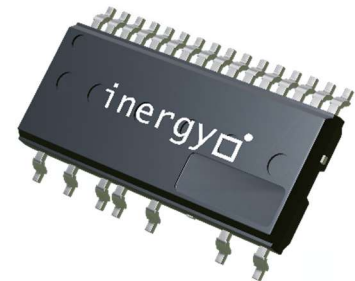

3. Applications

- Air Conditioner Out Door Unit
- Refrigerator Compressor
- Pumps
- Exhausted Fan

4. Pin Assignments

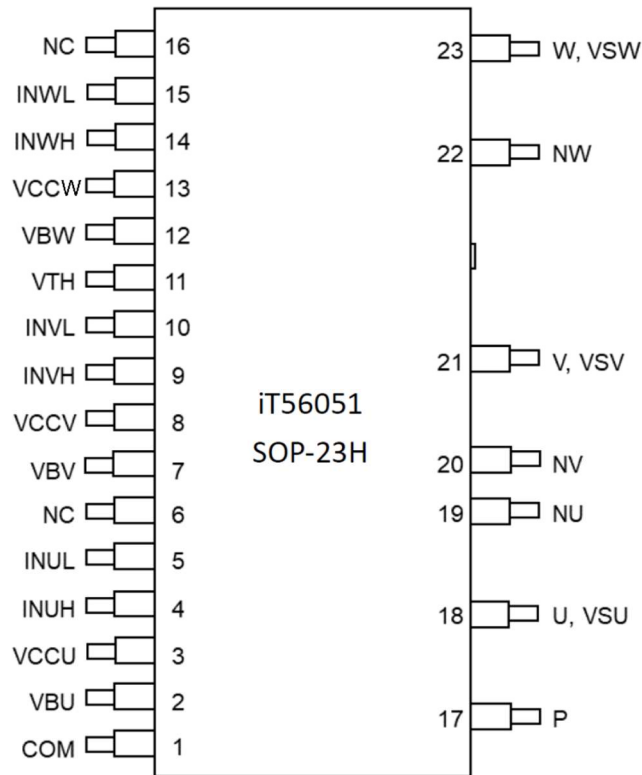

Fig.1 Pin Assignments (Top View)

5. Marking Information

Product Name	Marking
iT56051	<p>X: Date code</p>

6. Ordering Code

Ordering Code
iT56051

7. Pin Definitions

Pin No.	Symbol	Description
1	COM	Common Ground Pin
2	VBU	U-Phase High Side Floating Power Supply
3	VCCU	U-Phase Analog/ Logic Power Supply
4	INUH	U-Phase Signal input High Active for High Side
5	INUL	U-Phase Signal input High Active for Low Side
6	NC	No Connection
7	VBV	V-Phase High Side Floating Power Supply
8	VCCV	V-Phase Analog/Logic Power Supply
9	INVH	V-Phase Signal input High Active for High Side
10	INVL	V-Phase Signal input High Active for Low Side
11	VTH	Temperature Sensor Output
12	VBW	W-Phase High Side Floating Power Supply
13	VCCW	W-Phase Analog/Logic Power Supply
14	INWH	W-Phase Signal input High Active for High Side
15	INWL	W-Phase Signal input High Active for Low Side
16	NC	No Connection
17	P	DC Bus Power Supply
18	VSU	U-Phase Output & Floating Ground
19	NU	U-Phase Low Side MOSFET Source
20	NV	V-Phase Low Side MOSFET Source
21	VSV	V-Phase Output & Floating Ground
22	NW	W-Phase Low Side MOSFET Source
23	VSW	W-Phase Output & Floating Ground

8. Function Block

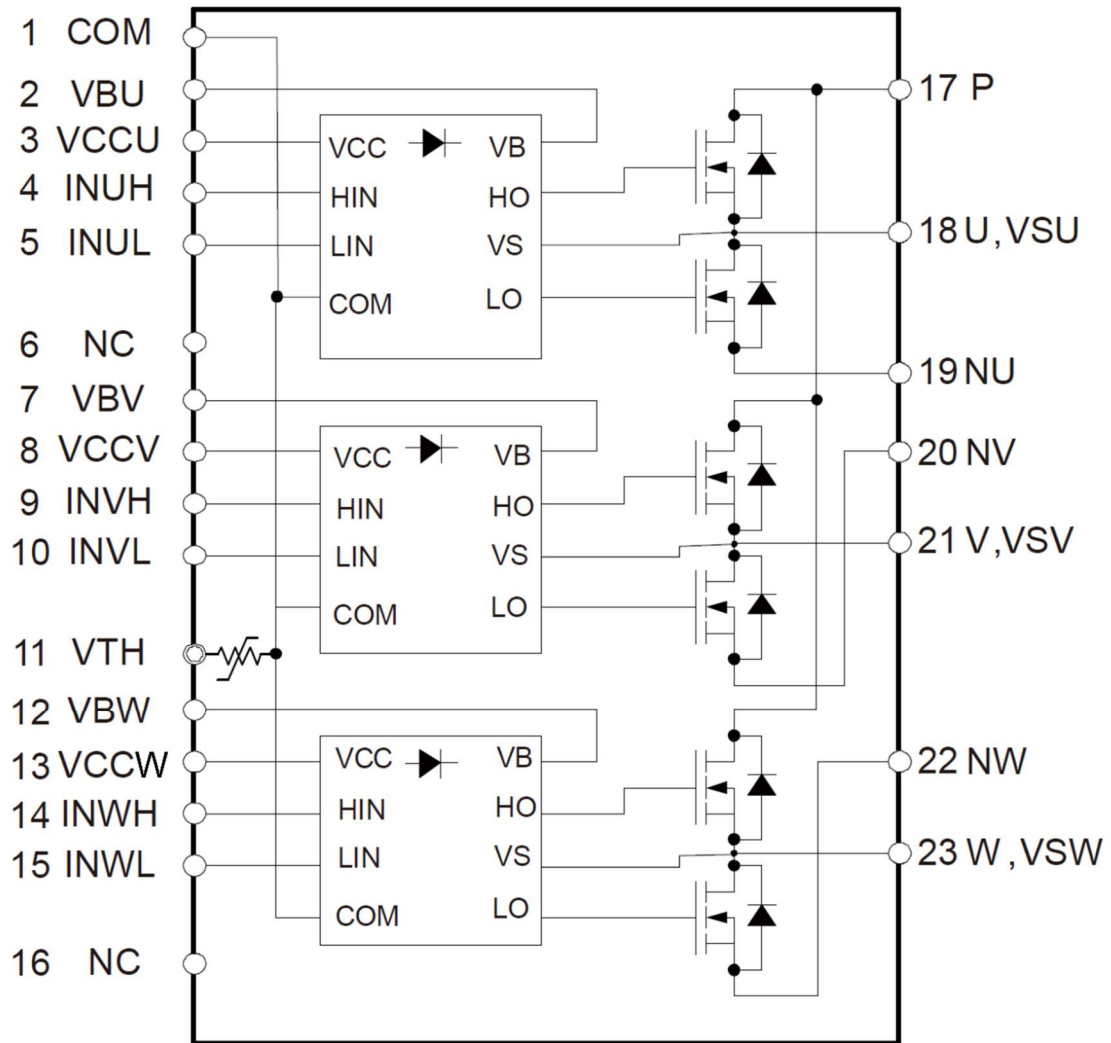

Fig.2 Pin Configuration and Internal Block Diagram

9. Typical Application Circuit

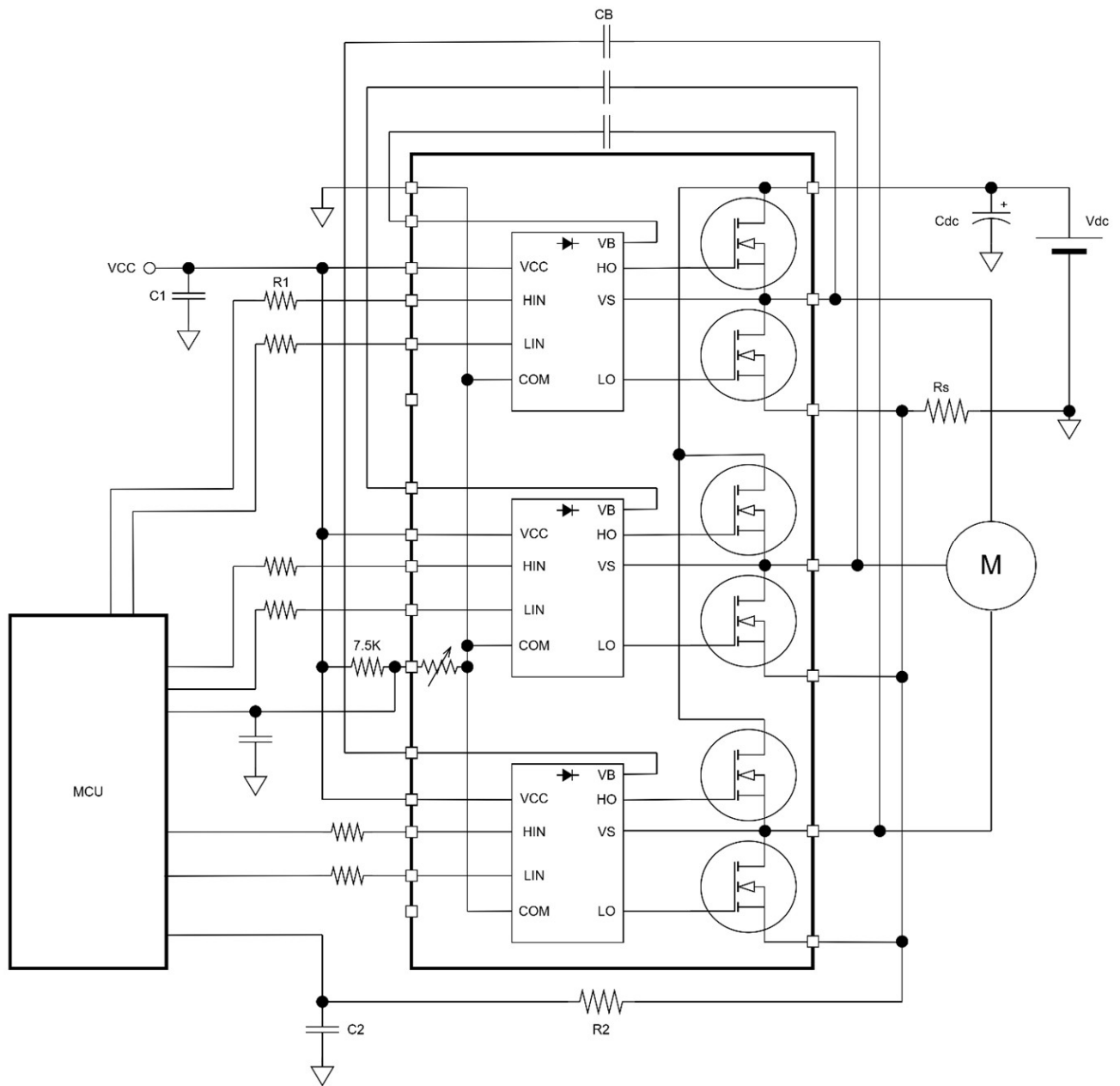

Fig.3 Application Circuit

Note 1 : Suggest that the $CB \geq 2.2\mu F$ and the $C1 \geq 10 * CB$ (22 μF).

Note 2 : PIN11 is the NTC output. If use the OTP function place a pull high resistor 7.5K to the Vcc.

Note 3 : Rs's & Cdc's GND directly connected to the power supply Vdc negative end, keep the loop as small as possible.

Note 4 : Between MCU & IPM, that could be placed the RC filter for the 6 PWM signal path. Suggest R1 is 100 Ohm to 1K Ohm.

10. Electrical Characteristics

10.1 Absolute Maximum Ratings

Absolute maximum ratings indicate sustained limits beyond which damage to the device may occur. All voltage parameters are absolute voltages referenced to COM, all currents are defined positive into any lead. The thermal resistance and power dissipation ratings are measured under board mounted and still air conditions. The ambient temperature is 25°C.

Symbol	Description	MIN	MAX	Unit
V _{CC}	Gate Driver Supply Voltage, V _{CCx}	-0.3	20	V
V _{BS}	Floating Supply Voltage from V _{Bx} to V _{Sx}	-0.3	20	V
V _{IN}	Signal Input Voltage, INxH & INxL	-0.3	V _{CC} +0.3	V
V _{PN}	DC Bus Supply Voltage from P to Nx	-0.6	600	V
I _O	Single MOSFET Output Current @ T _c = 25 °C	-	5.0	A
V _{ISO}	Insulation Voltage from Heatsink to Pin (60Hz Sine AC 1min.)	-	1500	V _{rms}
R _{thJC}	Thermal Resistance, Junction to Case	-	7.8	°C / W
T _J	Junction Temperature	-40	150	°C
T _S	Storage Temperature	-55	150	
T _L	Lead Temperature (Soldering 10 Seconds)	-	260	

10.2 Recommended Operating Conditions

For proper operation, the devices should be used under the following recommended conditions.

Symbol	Description	MIN	MAX	Unit
V _{CC}	Gate Driver Supply Voltage	12	18	V
V _{BS}	Floating Supply Voltage	11.5	16.5	V
V _{PN}	DC Bus Supply Voltage	-	400	V
V _{IN_H}	PWM Input Voltage Logic High	3.0	V _{CC}	V
V _{IN_L}	PWM Input Voltage Logic Low	0.0	0.6	V
t _{Dead}	Prevent High Side & Low Side Short through Dead Time	1	-	us
T _A	Ambient Temperature (*Note 1)	- 40	125	°C

*Note 1 : T_A is limited by T_J max., don't exceed its limitation.

10.3 D.C. and A.C. Characteristics

$V_{CC} = V_B = 15V$, $V_S = COM = 0V$, $T_A = 25\text{ }^\circ\text{C}$, unless otherwise specified.

10.3.1 Inverter Part

Symbol	Description	Condition	MIN	TYP	MAX	Unit
Inverter Part						
BV _{DSS}	D-S Breakdown Voltage	$V_{IN} = 0V, I_D = 250\mu A$	600	-	-	V
I _{DSS}	Drain Leakage Current	$V_{IN} = 0V, V_{DS} = 500V$	-	-	1	μA
R _{DS(ON)}	On State Resistance	$V_{CC} = V_{BS} = 15V,$ $V_{IN} = 5V, I_D = 1.2A$	-	1.1	1.3	Ω
V _{SD}	Diode Forward Voltage	$V_{CC} = V_{BS} = 15V,$ $V_{IN} = 0V, I_D = -1.2A$	-	-	1.5	V
T _{ON}	Turn on Propagation Delay	$V_{PN} = 310V$ $V_{CC} = V_{BS} = 15V$ $I_D = 1.0A$ $V_{IN} = 0V\sim 5V$	-	400	-	ns
T _{OFF}	Turn off Propagation Delay		-	400	-	ns
T _{RR}	Reverse Recovery Time		-	120	-	ns
E _{ON}	Turn on Power Loss		-	35	-	μJ
E _{OFF}	Turn off Power Loss		-	5	-	μJ

10.3.2 Control Part

Symbol	Description	Condition	MIN	TYP	MAX	Unit
Control Part						
V _{IH}	Input High Threshold Voltage	INHx / INLx to COM	2.0	-	-	V
V _{IL}	Input Low Threshold Voltage	INHx / INLx to COM	-	-	1.2	V
UV _{BSR}	VBS under Voltage Protection Reset	-	7.2	8.2	9.2	V
UV _{BSD}	VBS under Voltage Protection Detection	-	6.4	7.3	8.3	V
UV _{CCR}	VCC under Voltage Protection Reset	-	8.0	8.9	9.8	V
UV _{CCD}	VCC under Voltage Protection Detection	-	7.5	8.4	9.3	V
I _{QBS}	Quiescent V _{BO} Current	$V_{BS} = 15V, V_{IN} = 0V$ $V_{B(U)-U}, V_{B(V)-V}, V_{B(W)-W}$	-	20	-	μA
I _{QCC}	Quiescent V _{CC} Current	$V_{CC} = 15V, V_{IN} = 0V$	-	50	-	μA
I _{IN+}	Logic High Input Bias Current	$V_{IN} = 5V$	1.7	-	70	μA
I _{IN-}	Logic Low Input Bias Current	$V_{IN} = 0V$	-	0	5	μA
R _{TH}	NTC Resistance	T _{TH} = 25 $^\circ\text{C}$	-	47	-	K Ω
		T _{TH} = 100 $^\circ\text{C}$	-	3.1	-	K Ω

10.3.3 Bootstrap Diode

Symbol	Description	Condition	MIN	TYP	MAX	Unit
Bootstrap Diode						
R_{BS}	Bootstrap Current Limit Resistance	-	-	310	-	Ω
V_{BDF}	Bootstrap Diode forward Voltage	$I_F=1mA$	-	0.7	-	V
V_{BDR}	Bootstrap Diode Reverse Breakdown Voltage	$I_R=10\mu A$	600	-	-	V

The switching time definition and evaluation method are shown in the figures below.

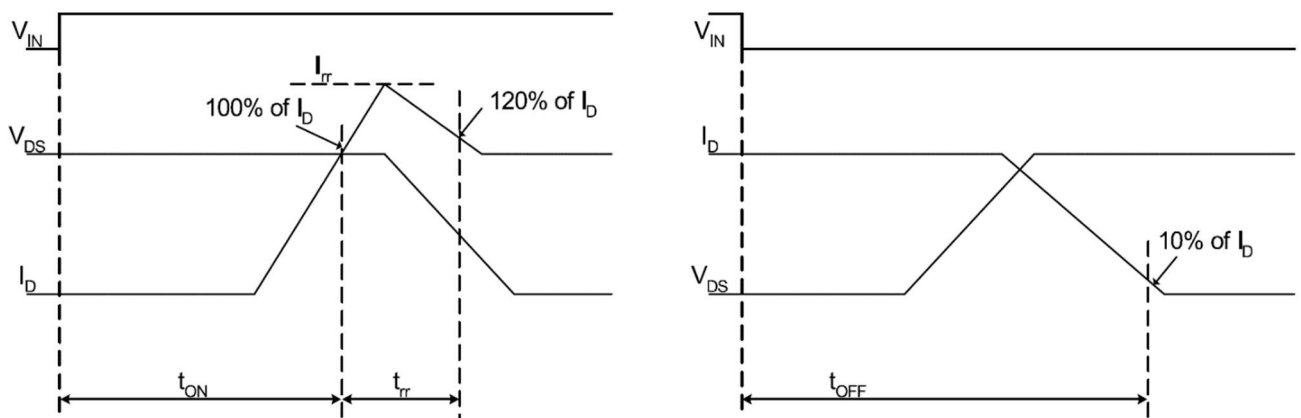

Fig.4 Switching Time Definitions

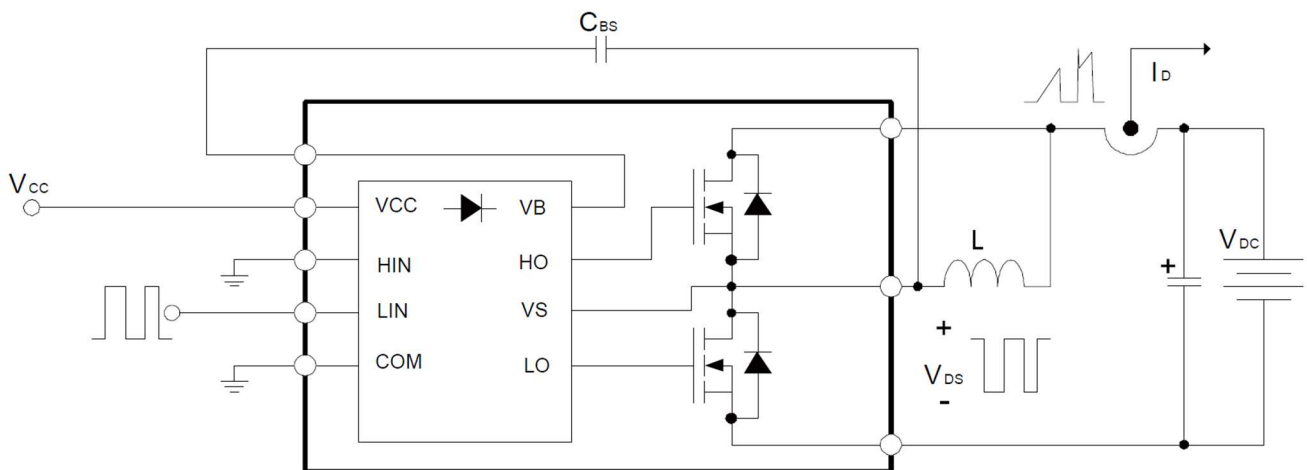

Fig.5 Switching Test Circuit (Low-side)

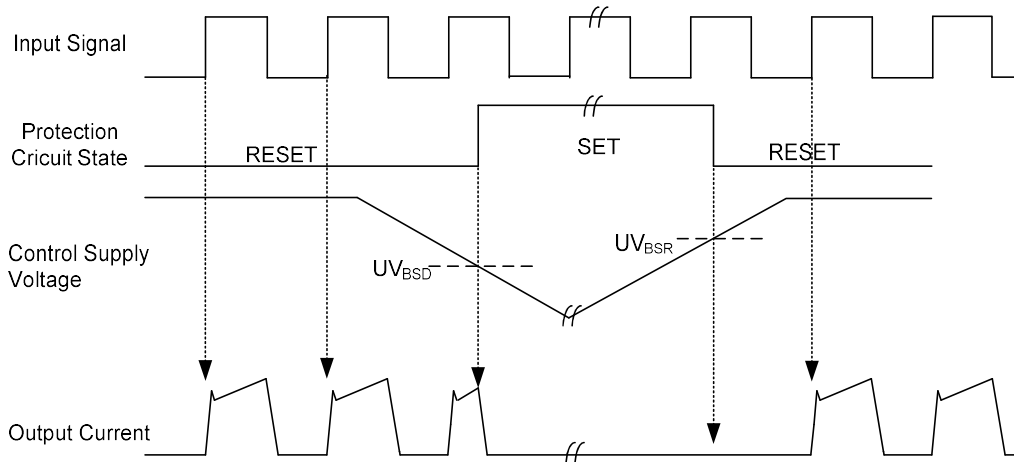

Fig.6 Under-Voltage Protection (Low-side)

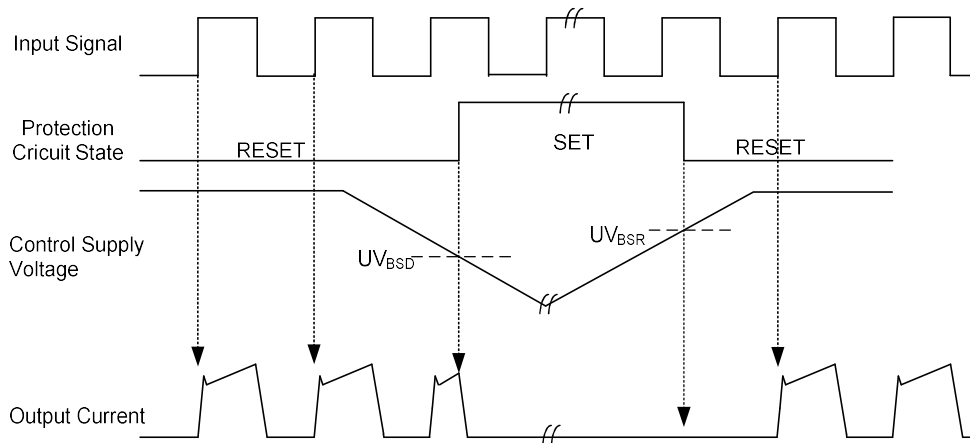
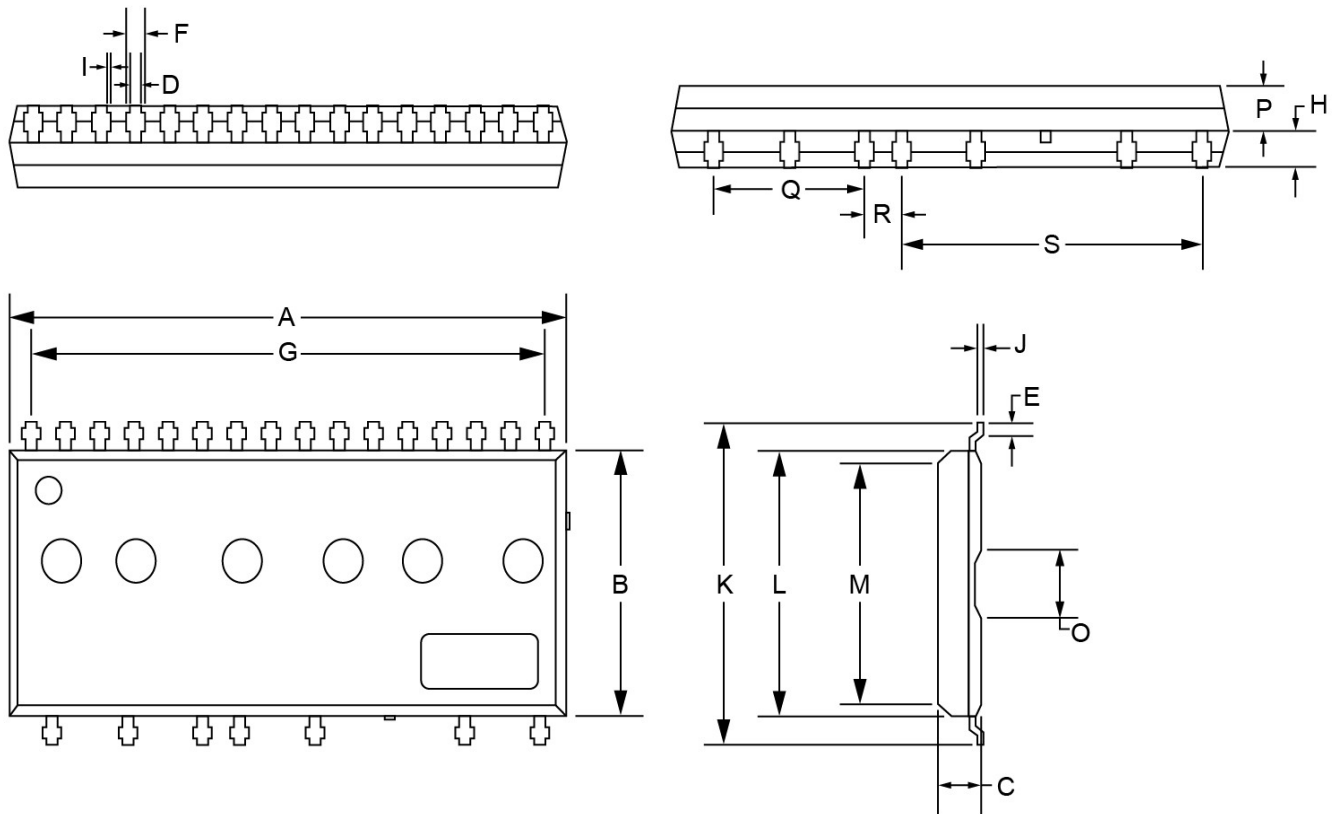

Fig.7 Under-Voltage Protection (High-side)

11. Package Information

SOP-23H Outline Dimensions



SYMBOL	Dimensions in mm	
	MIN	MAX
A	28.80	29.20
B	11.80	12.20
C	3.05	3.25
D	0.50	0.70
E	1.05	1.75
F	0.75	1.05
G	26.37	26.97
H	1.15	1.45
I	0.00	0.15
J	0.40	0.60
K	16.70	17.30
L	10.80	11.20
M	9.90	10.30
O	2.58	2.78
P	1.70	2.00
Q	7.60	8.00
R	1.75	2.15
S	15.40	15.80

Important Notice

1. inergy Technology Inc. reserves the right to make corrections, modifications, enhancements, improvements, and other changes to its products and services at any time and to discontinue any product or service without notice. Customers should obtain the latest relevant information before placing orders and should verify that such information is current and complete.
2. The Products of inergy Technology Inc. have been tested, verified and passed by our specifications and standards, and are 100% inspected before delivery from the factory. It is strongly recommended that the customers shall perform verifications of the functionality, compatibility, and reliability of the environment or platform that you used. inergy Technology Inc. would not be liable for or guarantee anything that is related to the functionality, compatibility, and reliability of the environment or platform used by the customers.