

Digital Single Phase BLDC All in one Motor Controller

1. Description

The iT8330E is a single phase, brushless DC motor controller. It is composed of MOSFET, gate driver and control logic which can provide minimal components of total BOM to save total cost.

The iT8330E provides various parameters to tune motor efficiently and quickly, ex: poles, Lead Angel, target speed and PWM duty ...etc.

The iT8330E is equipped with TSD, OCP, OVP, Lockout protections

The iT8330E can drive AC synchronous motor by sinusoidal waveform with 50Hz or 66Hz.

All the parameters shall be set via inergy's software "INGUI".

2. Applications

BLDC motors and fans

3. Features

- Direct PWM control
- DC VSP control 0.2V~3.3V
- Supports Hall IC
- Wide Range 3.0V to 28V Operating Input
- Integrated Power MOSFETs
- Programmable Multi Points Speed Curve
- Adjustable Lead Angle $\pm 45^\circ$
- Selectable Lockout Detection Time and Automatic Recovery Time
- Adjustable Silence Current Control
- Selectable FG/Alarm/RD Signal Output
- 1KHz~100KHz PWM Input Frequency Range
- 25K/50KHz Output Switching Frequency
- Cycle by Cycle Current Limit
- Selectable Open Loop and Close Loop
- Adjustable Input Duty and Output Duty Slope
- Soft Start and Kick Start
- Low Voltage Kick Duty Compensation
- TSD, OCP, OVP and Automatic Recovery

4. Pin Assignments

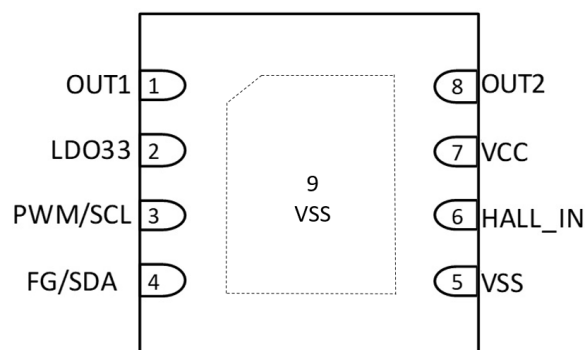

DFN3X3 8L

5. Marking Information

Ordering code	Marking
iT8330E	 <p>X : Date code Y : Checksum □□ : Internal code</p>

Note: inergy defines " Green " as lead-free (RoHS compliant) and halogen free (Br or Cl does not exceed 900 ppm by weight in homogeneous material and total of Br and Cl does not exceed 1500 ppm by weight; Follow IEC 61249-2-21 and IPC / JEDEC J-STD-020C)

6. Pin Definitions

Pin No.	Symbol	Description	For Synchronous Motor
1	OUT1	Driving motor output	Driving motor output
2	LDO33	DC3.3V output	DC3.3V output
3	PWM/SCL	Direct PWM input / SCL	Switch on : 5V/off : 0V
4	FG/SDA	Speed signal output / SDA	N/A
5	VSS	Ground pin	Ground pin
6	HALL_IN	External hall IC signal in	Frequency input
7	VCC	Power supply pin	Power supply pin
8	OUT2	Driving motor output	Driving motor output
9	VSS	Ground pin (Exposed pad)	Ground pin (Exposed pad)

7. Block Diagram

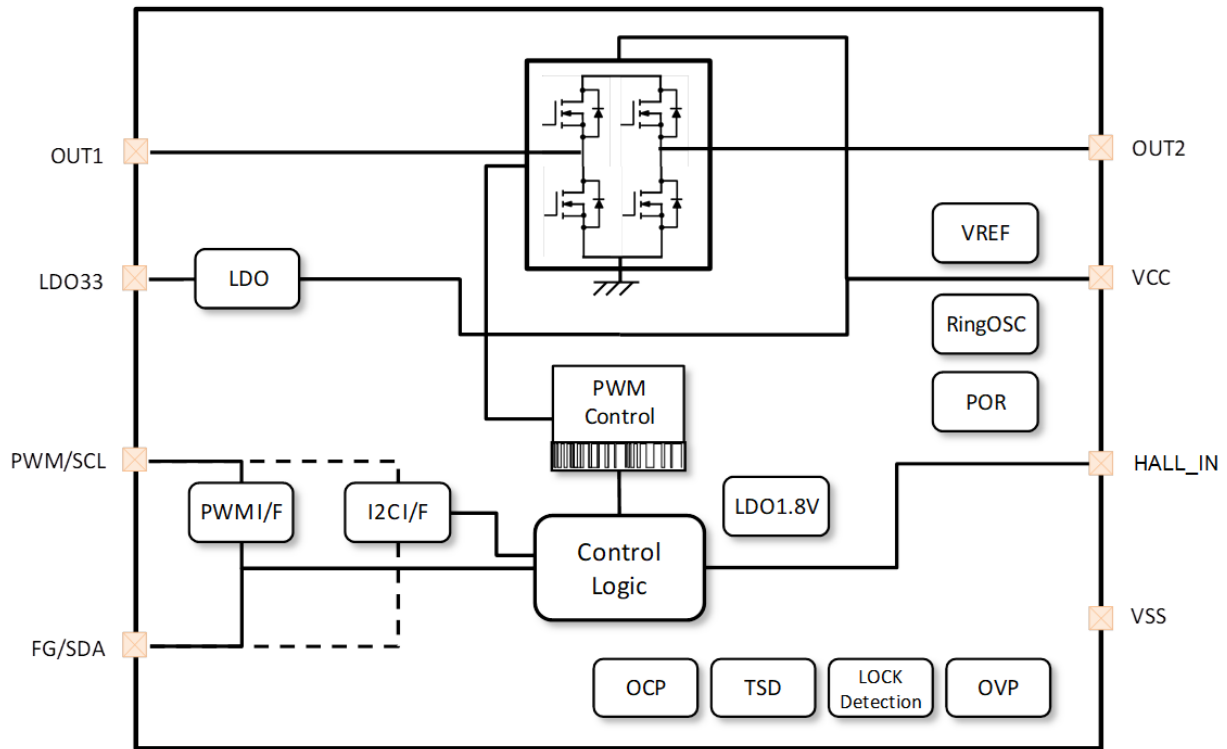

8. Absolute Maximum Ratings

Absolute maximum ratings indicate sustained limits beyond which damage to the device may occur. All voltage parameters are absolute voltages referenced to GND, all currents are defined positive into any lead. The thermal resistance and power dissipation ratings are measured under board mounted and still air conditions.

Symbol	Parameter	Min	Max	Unit
V _{CC}	Supply Voltage	-0.3	35	V
I _O	Output Current (peak, <100ms)	-	1.6	A
P _D	Package power dissipation @ T _A ≤ + 25 °C	-	2.5	W
V _{PWM}	PWM/SCL signal input voltage	-0.3	6	V
V _{FG}	FG/Alarm/RD signal output voltage	-0.3	35	V
I _{FG}	FG/Alarm/RD signal sink current	-	0.01	A
R _{thJA}	Thermal resistance, junction to ambient	-	120	°C / W
R _{thJC}	Thermal resistance, junction to case	-	40	°C / W
T _J	Junction temperature	-	150	°C
T _S	Storage temperature	-55	150	
T _L	Lead temperature (soldering 10 seconds)	-	260	

9. Recommended Operating Conditions

Symbol	Parameter	Min	Max	Unit
V _{CC}	Operating supply voltage	3.0	28	V
V _{PWM}	PWM input voltage	-0.3	5.5	V
V _{FG}	FG/Alarm/RD signal output voltage	-0.3	28	V
D _{PWM}	Duty of PWM input	0	100	%
F _{PWMIN}	Frequency of PWM input	1K	100K	Hz
T _A	Ambient temperature (*1)	- 40	125	°C

*1 Note : Please do not exceed T_J limitation

10. Electrical Characteristics

$V_{CC}=24V$, $T_A=25\text{ }^\circ\text{C}$, unless otherwise specified.

Symbol	Parameter	Conditions	Min	Typ	Max	Unit
I_{CC}	Circuit Current	$V_{CC}=24V$				mA
TH_{PG}	Vcc power good threshold		-15%	2.8	+15%	V
HYS_{PG}	Vcc power good hysteresis			0.2		V
TH_{OV}	Vcc over voltage threshold	Select by GUI	31.5		33.5	V
HYS_{OV}	Vcc Over voltage hysteresis			1		V
TH_{TSD}	Thermal shutdown threshold	Select by GUI	100		175	$^\circ\text{C}$
HYS_{TSD}	Thermal shutdown hysteresis			50		$^\circ\text{C}$
TH_{TAM}	Thermal alarm threshold	Select by GUI	100		175	$^\circ\text{C}$
HYS_{TAM}	Thermal alarm hysteresis			25		$^\circ\text{C}$
V_{LDO33}	LDO33 output voltage	$C_{Load}=47\text{nf}$ $I_{O_{MAX}}=10\text{mA}$		3.3		V
V_{PWMH}	PWM input high voltage		2.6		5.5	V
V_{PWML}	PWM input low voltage		-0.3		0.8	
F_{PWM}	PWM input frequency		1		100	kHz
R_{PWM}	PWM input internal pull-up resistance			20		k Ω
R_{PWM}	PWM input internal pull-down resistance			800		k Ω
V_{FGL}	FG low level voltage	$I=10\text{mA}$		0.3		V
R_{FG}	Internal resistance of FG	$I_{FG}=10\text{mA}$		12		Ω
R_{on}	High side + Low side resistance	$I_o=0.5A$ $V_{CC}=12V$		0.6		Ω
I_{OC}	Over current threshold	Select by GUI	1.2		1.6	A
I_{lim}	Output current limit range	Select by GUI	0.1		1.2	A
F_{osc}	Internal oscillator frequency		-5%	26	+5%	MHz
F_{PWM}	PWM output frequency	Select by GUI	-5%	25	+5%	kHz
			-5%	50	+5%	
LA	Lead Angle	Program by GUI	-45		+45	$^\circ$
T_{locd}	Lockout detect time	0.25/0.5sec	-5%	0.25	+5%	sec
T_{lodr}	Lock recovery time	2.5/7/7.5/10sec	-5%	2.5	+5%	sec

11. Application Circuit

<Typical>

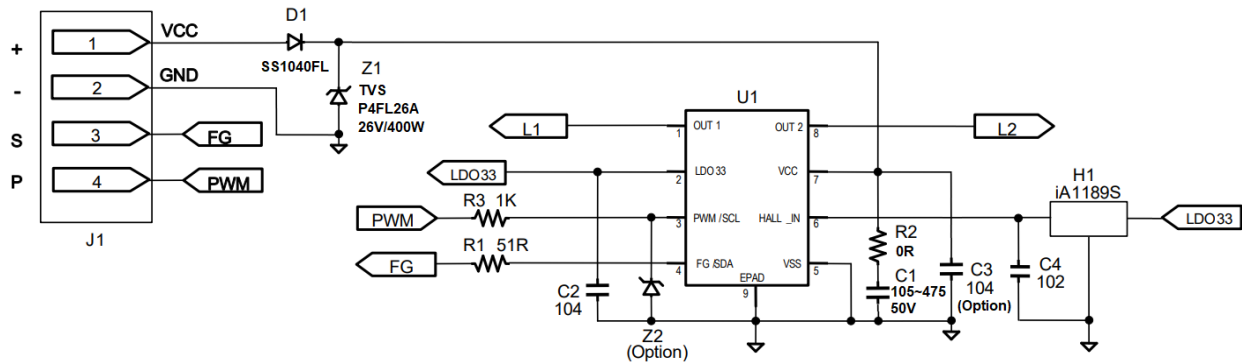

Note :

1. (IMPORTANT) C1 must be placed as close as possible to VCC pin.
2. Z1 must be TVS. Withstand voltage depends on application.
3. C3 is optional. C3 must be placed as close as possible to VCC pin.
4. Z2 is optional. It can be removed if PWM input voltage will not exceed to 5.5V.
5. R1 and R3 are optional for ESD protection.
6. The value of R3 will affect VPWMH and VPWML of PWM.

12. I/O Equivalent Circuit

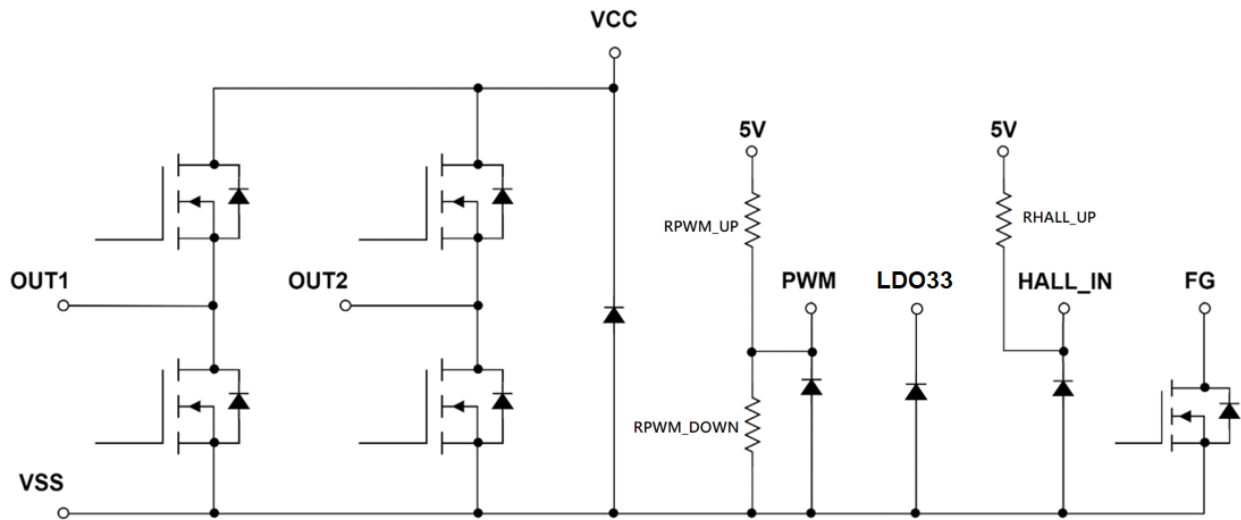

13. Package Information

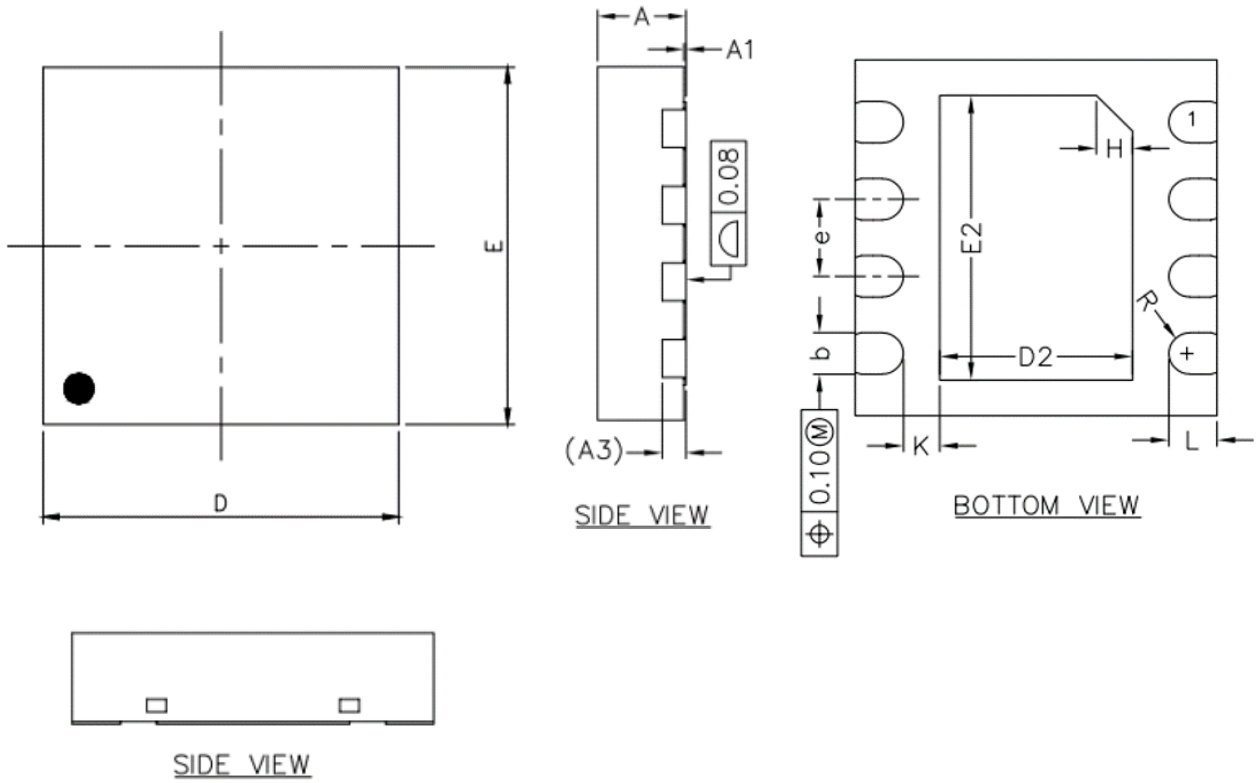

SYMBOL	Dimension in mm		
	MIN.	NOM.	MAX.
A	0.70	0.75	0.90
A1	0.00	0.02	0.05
A3	0.20 REF		
b	0.25	0.35	0.40
D	2.90	3.00	3.10
E	2.90	3.00	3.10
D2	1.50	1.60	1.85
E2	1.95	2.40	2.55
e	0.55	0.65	0.75
H	0.30 REF		
K	0.20	0.30	0.40
L	0.30	0.40	0.50
R	0.16	-	-

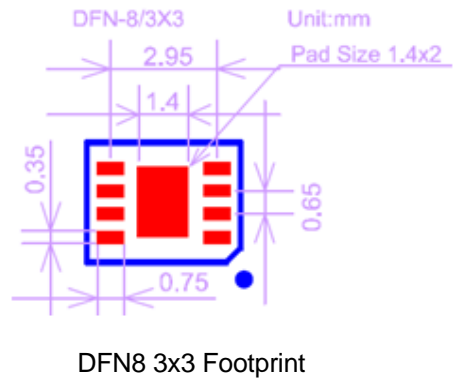

Important Notice

1. inergy Technology Inc. reserves the right to make corrections, modifications, enhancements, improvements, and other changes to its products and services at any time and to discontinue any product or service without notice. Customers should obtain the latest relevant information before placing orders and should verify that such information is current and complete.
2. The Products of inergy Technology Inc. have been tested, verified and passed by our specifications and standards, and are 100% inspected before delivery from the factory. It is strongly recommended that the customers shall perform verifications of the functionality, compatibility, and reliability of the environment or platform that you used. inergy Technology Inc. would not be liable for or guarantee anything that is related to the functionality, compatibility, and reliability of the environment or platform used by the customers.