

Digital Single Phase BLDC All in one Motor driver

1. Description

The iT8320E is a single phase, brushless DC motor controller. It is composed of MOSFET, gate driver and control logic which can provide minimal components of total BOM to save total cost.

The iT8320E provides various parameters to tune motor efficiently and quickly, ex: poles, Lead Angel, target speed and PWM duty ...etc.

The iT8320E is equipped with TSD, OCP, OVP, Lockout protections

2. Applications

BLDC motors and fans

3. Features

- Direct PWM control
- Supports Hall IC
- Wide Range 3.5V to 16V Operating Input
- Integrated Power MOSFETs
- Programmable Multi Points Speed Curve
- Adjustable Lead Angle $\pm 45^\circ$
- Adjustable Lockout Detection and Automatic Recovery
- Adjustable Silence Current Control
- Selectable FG/Alarm/RD Signal Output
- 1KHz~100KHz PWM Input Frequency Range
- 25K/50KHz Output Switching Frequency
- Cycle by Cycle Current Limit
- Selectable Open Loop and Close Loop
- Adjustable Input Duty and Output Duty Slope
- Soft Start and Kick Start
- TSD, OCP, OVP and Automatic Recovery

4. Pin Assignments

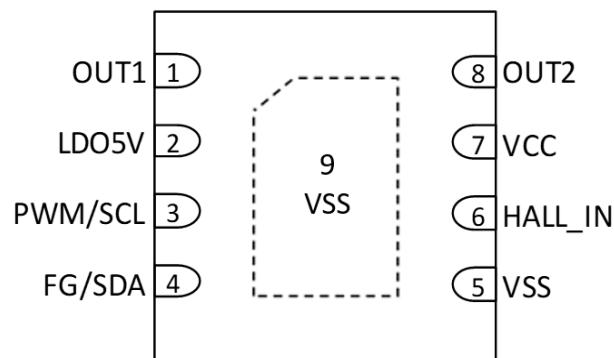

DFN3x3 8L
(3x3mm)

5. Marking Information

Ordering code	Marking
iT8320E	 <p>X : Date code Y : Checksum □□ : Internal code</p>

Note: inergy defines " Green " as lead-free (RoHS compliant) and halogen free (Br or Cl does not exceed 900 ppm by weight in homogeneous material and total of Br and Cl does not exceed 1500 ppm by weight; Follow IEC 61249-2-21 and IPC / JEDEC J-STD-020C)

6. Pin Definitions

Pin No.	Symbol	Description
1	OUT1	Driving motor output
2	LDO5V	DC5V output
3	PWM/SCL	Direct PWM input/ SCL
4	FG/SDA	Speed signal output / SDA
5	VSS	Ground pin
6	HALL_IN	External hall IC signal in
7	VCC	Power supply pin
8	OUT2	Driving motor output
9	VSS	Ground pin. (Exposed pad)

7. Block Diagram

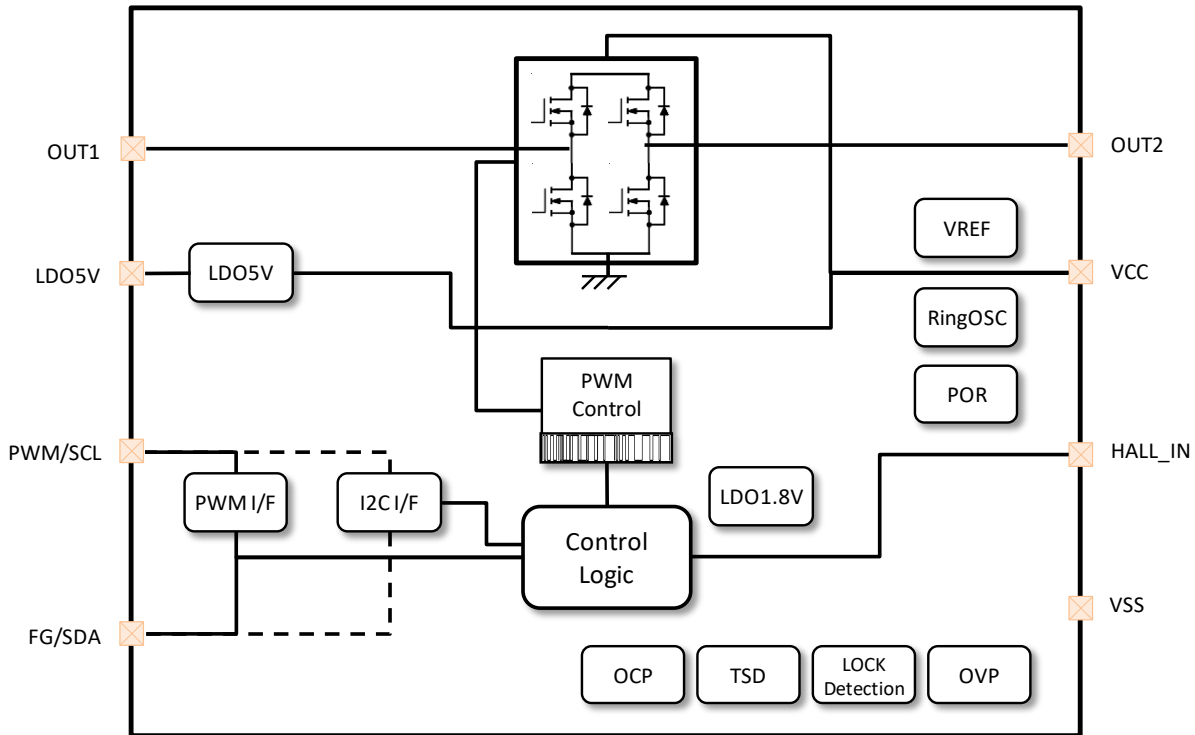

8. Absolute Maximum Ratings

Absolute maximum ratings indicate sustained limits beyond which damage to the device may occur. All voltage parameters are absolute voltages referenced to COM, all currents are defined positive into any lead. The thermal resistance and power dissipation ratings are measured under board mounted and still air conditions.

Symbol	Parameter	Min	Max	Unit
V _{CC}	Supply Voltage	-0.3	22	V
I _{Oavg}	Output average current (*1)		0.8	A
I _O	Output Current (peak, <100ms)		2.4	A
P _D	Package power dissipation @ T _A ≤ + 25 °C		2.5	W
V _{PWM}	PWM/SCL signal input voltage	-0.3	6	V
V _{FG}	FG/Alarm/RD signal output voltage	-0.3	18	V
I _{FG}	FG/Alarm/RD signal sink current		0.01	A
R _{thJA}	Thermal resistance, junction to ambient (DFN-8L 3*3)		50	°C / W
T _J	Junction temperature		150	°C
T _S	Storage temperature	-55	150	
T _L	Lead temperature (soldering 10 seconds)		260	

*1 Note : Please do not exceed T_j limitation

9. Recommended Operating Conditions

Symbol	Parameter	Min	Max	Unit
V _{CC}	Operating supply voltage	3.5	16	V
V _{PWM}	PWM input voltage	-0.3	5.5	V
V _{FG}	FG/Alarm/RD signal output voltage	-0.3	16	V
D _{PWM}	Duty of PWM input	0	100	%
F _{PWMIN}	Frequency of PWM input	1K	100K	Hz
T _A	Ambient temperature (*1)	- 40	125	°C

*1 Note : Please do not exceed T_j limitation

10. Electrical Characteristics

$V_{CC}=12V$, $T_A = 25^\circ C$, unless otherwise specified.

Symbol	Parameter	Conditions	Min	Typ	Max	Unit
TH _{PG}	Vcc power good threshold		-15%	3	+15%	V
HYS _{PG}	Vcc power good hysteresis		0.2		0.4	V
TH _{ov}	Vcc over voltage threshold	Select by GUI	19.5		21.5	V
HYS _{ov}	Vcc Over voltage hysteresis			1		V
TH _{tsd}	Thermal shutdown threshold	Select by GUI	125		175	°C
HYS _{tsd}	Thermal shutdown hysteresis			50		°C
TH _{tam}	Thermal alarm threshold	Select by GUI	100		150	°C
HYS _{tam}	Thermal alarm hysteresis			25		°C
V _{PWMH}	PWM input high voltage		2.6		5.5	V
V _{PWML}	PWM input low voltage		-0.3		0.8	
F _{PWM}	PWM input frequency		1		100	kHz
R _{PWM_UP}	PWM input internal pull-up resistance			20		kΩ
R _{PWM_DOWN}	PWM input internal pull-down resistance			800		kΩ
V _{FGL}	FG low level voltage	I=10mA		0.3		V
I _{cc}	Circuit Current	V _{cc} =12V		8		mA
R _{on}	High side + Low side resistance	I _o =0.5A/V _{cc} =12V T _a =25°C		0.5		Ω
I _{oc}	Over current protection threshold				2.4	A
I _{lim}	Output current limit range	Select by GUI	0.6		2.1	A
F _{osc}	Internal oscillator frequency		-5%	26	+5%	MHz
F _{PWM}	PWM output frequency		-5%	25	+5%	kHz
			-5%	50	+5%	
LA	Lead Angle	Program by GUI	-45		+45	°
T _{locd}	Lockout detect time	0.25/0.5sec	-5%	0.25	+5%	sec
T _{lodr}	Lock recovery time	2.5 / 5 / 7.5 / 10sec	-5%	2.5	+5%	sec

11. Application Circuit

Typical

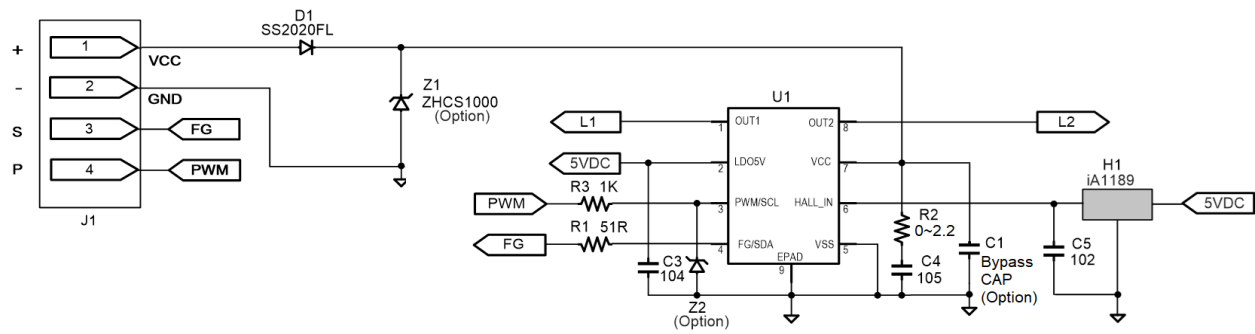

NOTE :

1. (IMPORTANT) C4 must be placed as close as possible to VCC pin.
2. C1 is optional. It must be placed as close as possible to VCC pin.
3. Z2 is optional. It can be removed if PWM input voltage will not exceed to 5.5V.
4. R1 and R3 are optional for ESD protection.
5. The value of R3 will affect V_{PWMH} and V_{PWML} of PWM.

12. I/O Equivalent Circuit ESD Protection

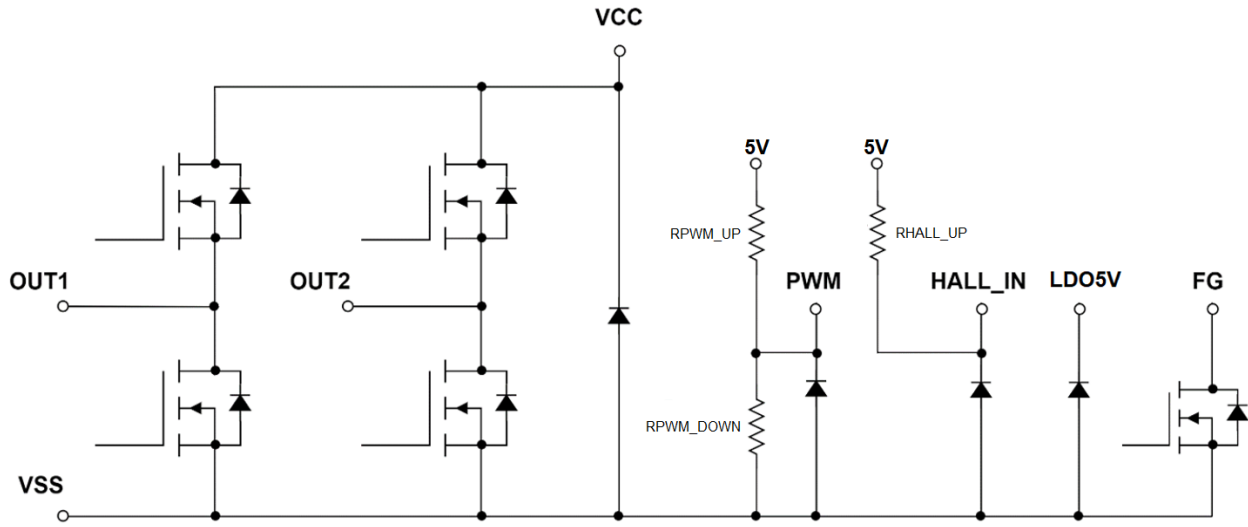

13. Package Information

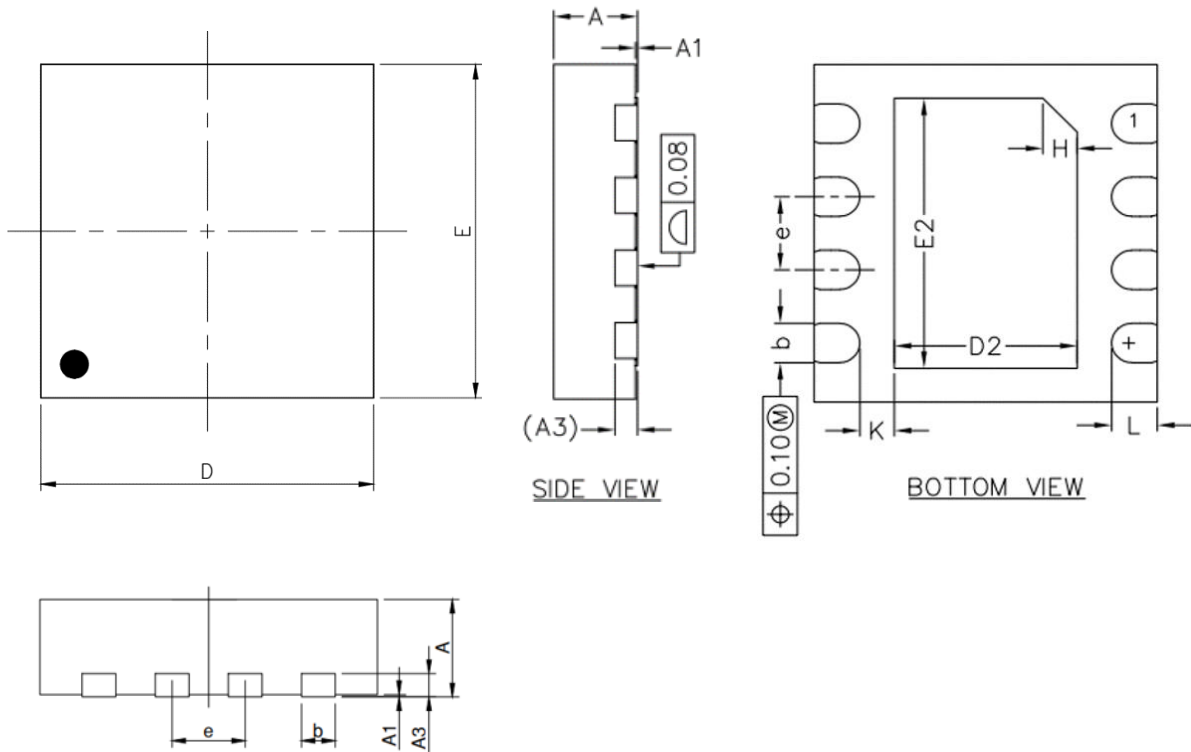

SYMBOL	Dimension in mm		
	MIN.	NOM.	MAX.
A	0.70	0.75	0.90
A1	0.00	0.02	0.05
A3	0.20 REF		
b	0.25	0.35	0.40
D	2.90	3.00	3.10
E	2.90	3.00	3.10
D2	1.50	1.60	1.85
E2	1.95	2.40	2.55
e	0.55	0.65	0.75
H	0.30 REF		
K	0.20	0.30	0.40
L	0.30	0.40	0.50

Important Notice

1. inergy Technology Inc. reserves the right to make corrections, modifications, enhancements, improvements, and other changes to its products and services at any time and to discontinue any product or service without notice. Customers should obtain the latest relevant information before placing orders and should verify that such information is current and complete.
2. The Products of inergy Technology Inc. have been tested, verified and passed by our specifications and standards, and are 100% inspected before delivery from the factory. It is strongly recommended that the customers shall perform verifications of the functionality, compatibility, and reliability of the environment or platform that you used. inergy Technology Inc. would not be liable for or guarantee anything that is related to the functionality, compatibility, and reliability of the environment or platform used by the customers.